

SchuF FETTEROLF Worldwide

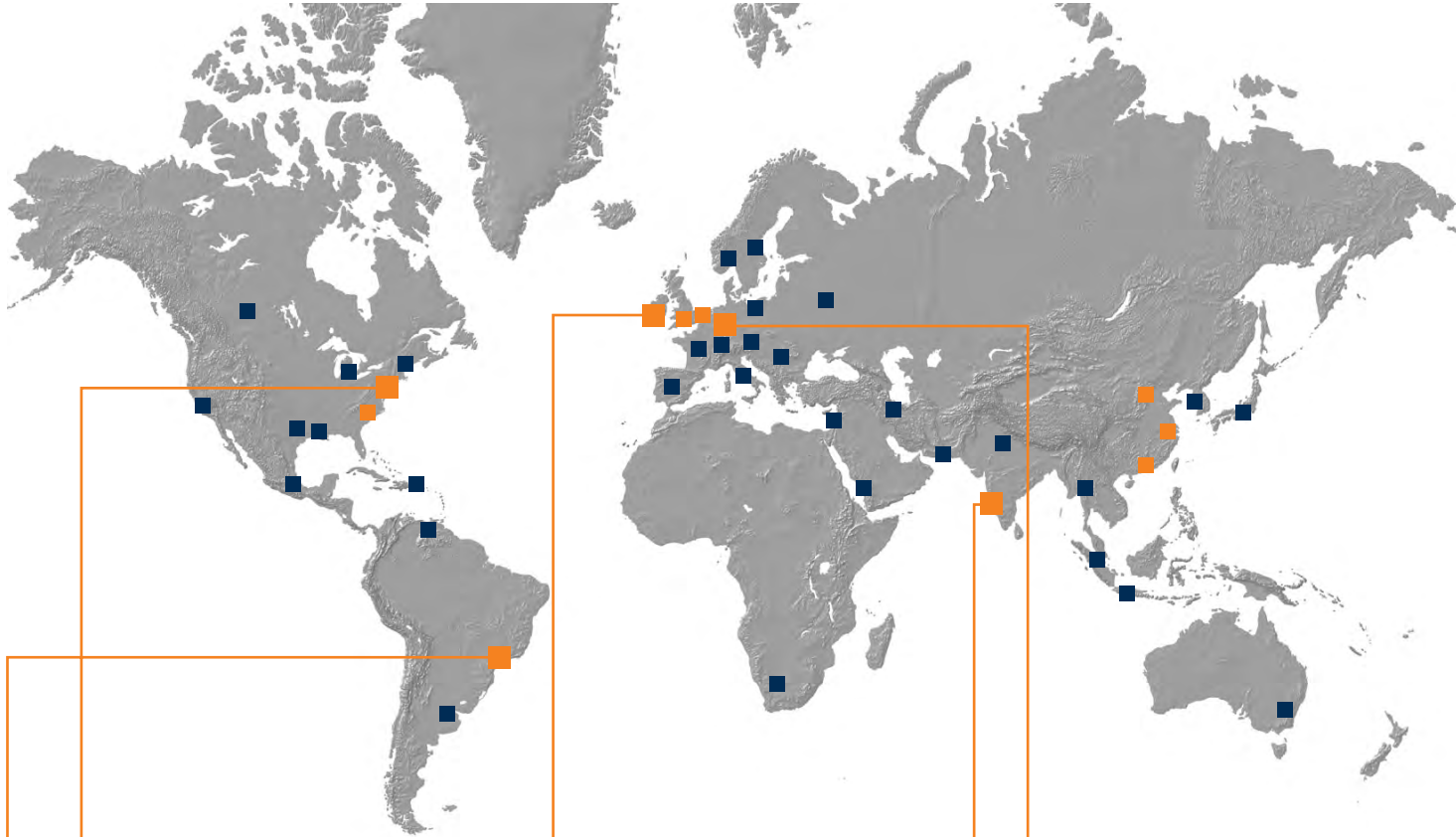

www.schuf.com · www.schuf.de

USA



Fetterolf Corporation, Inc.
 phone: +1 610 584-1500
 fax: +1 610 584-5904
 info@fetterolfvalves.com
SchuF (USA) Inc.
 phone: +1 843 8813345
 fax: +1 843 8816121
 sales@schuf.us

IRELAND



SchuF Valve Technology GmbH
 phone: +353 (0)21 4837000
 fax: +353 (0)21 4837030
 sales@schuf.ie

GERMANY



SchuF Chemieventile Vertriebs GmbH
 phone: +49 (0)6198 571100
 fax: +49 (0)6198 571200
 verkauf@schuf.de

BRAZIL



Fetterolf SchuF do Brazil Ltda
 phone: +55 19 3936 9090
 fax: +55 19 3935 3215
 fbvendas@fetterolf.com.br

Your Local Agent:

INDIA



SchuF Speciality Valves India Pvt. Ltd.
 phone: +91 421 2264600
 fax: +91 421 2362018
 sales@schuf-india.com

Disc Bottom Outlet Valves

KEGELBODENVENTILE



SchuF  FETTEROLF

Disc Bottom Outlet Valve – General Overview

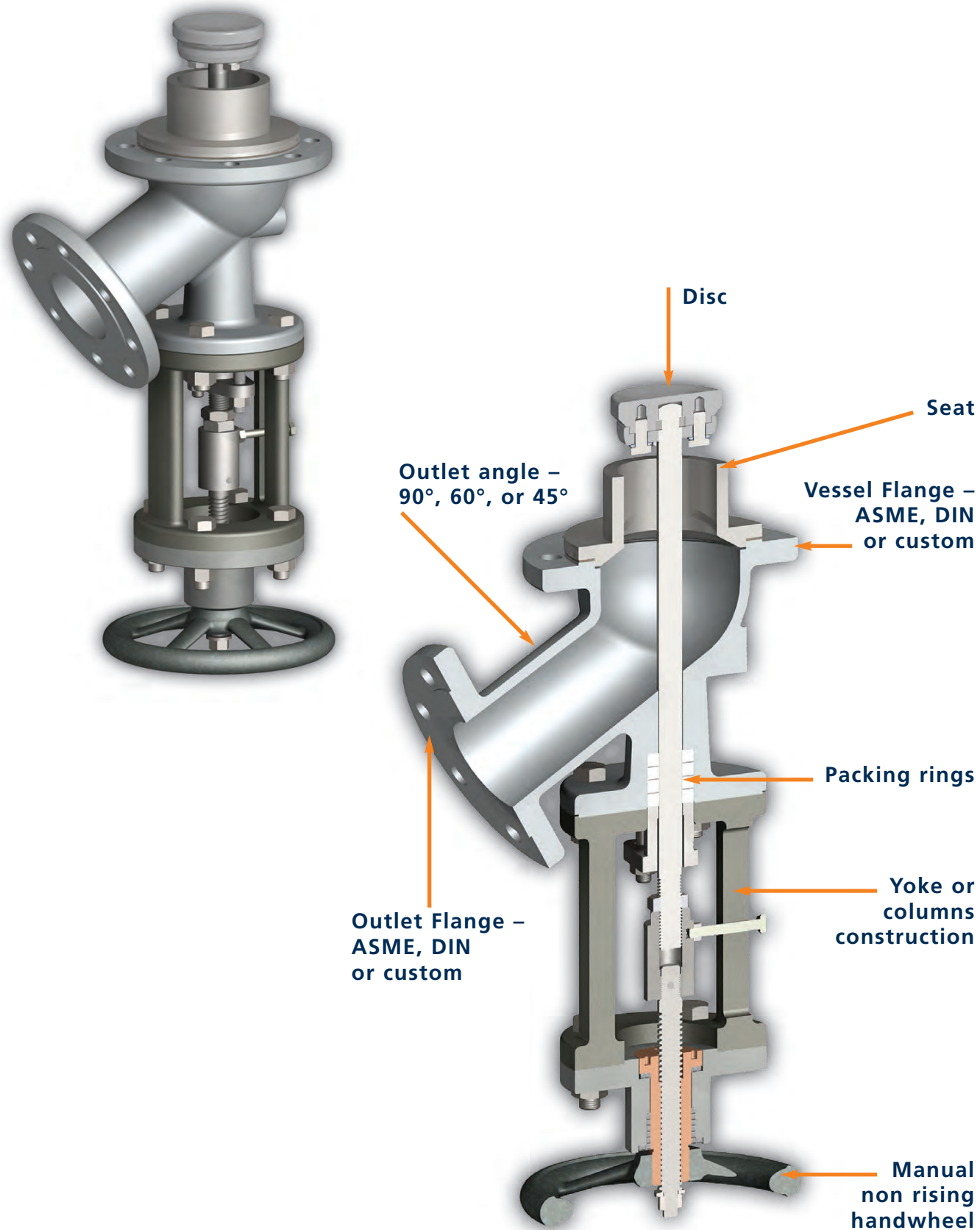

Development of Bottom Outlet Valves

Bottom Outlet or Drain Valves have been extensively used in the chemical and related industries for almost 100 years. Invented by SchuF in 1923, their initial application was to replace the very simple wooden plug used to close or drain tanks, vessels or pipelines. Their introduction made it possible to drain vessels containing dangerous substances, and handle media under high pressure or temperature safely. The other key benefit for early users of Bottom Outlet Valves was the ability to ensure dead space free draining of vessels or reactors.

Industry Application

Today, Bottom Outlet Valves (BOV) have found applications beyond the chemical and petrochemical industry. They are suitable for pharmaceutical and biotech applications where cross contamination must be avoided. They have also found a place in abrasive slurry and high temperature environments such as in the coal liquefaction and alumina industries.

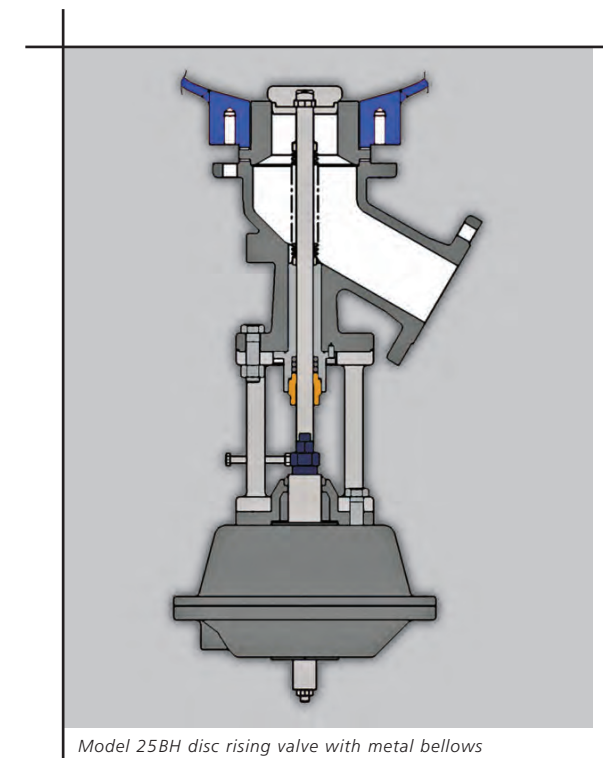

Bottom Outlet Valve Types

SchuF has developed a diverse range of Bottom Outlet Valves which include both Disc and Piston (or Ram) categories. The fundamental difference between the two are:

- Disc valves have a shorter length and are therefore ideal where space is limited or weight is a concern. The shorter stroke means that smaller, lighter and faster actuators can be used, saving cost and weight.
- Ram Piston valves have full bore unimpeded flow and are more suitable for vessels that need to be drained or flushed quickly, for highly viscous media or where large samples need to be taken.

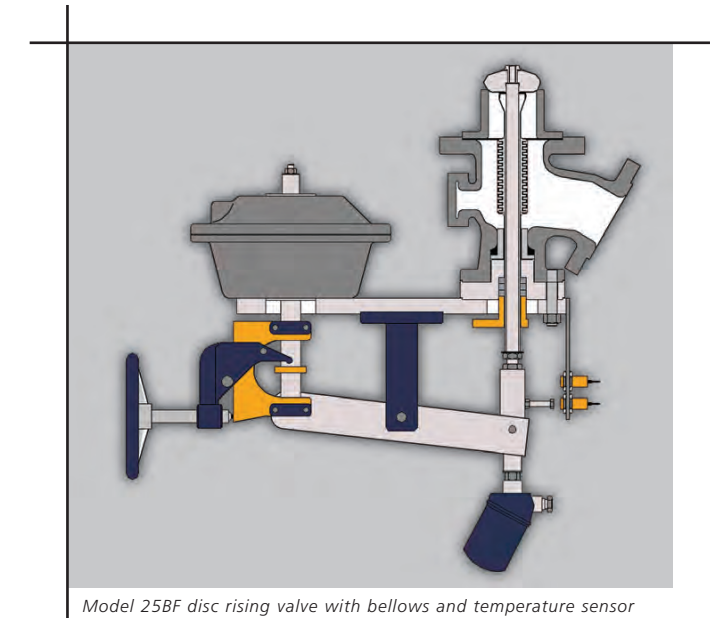

Disc Bottom Outlet Valve Models

Disc Bottom Outlet Valves can be supplied as a disc rising or disc lowering model.

The **disc rising** valve models 19 (same size inlet/outlet) and 25 (bigger size inlet than outlet) are most suitable for media where solid materials or crystals can form at the exit point of the vessel. As the disc opens into the vessel automatic crust breaking takes place. The disc rising valve is also normally a flow to close design, which aids sealing performance.

Disc Bottom Outlet Valve – General Overview

The **disc lowering** valve models 18 (different size inlet/outlet) and 24 (bigger size inlet than outlet) can be used on vessels with low mounted agitators, as it is non intrusive. Disc lowering valves can also be combined with sampling valves.

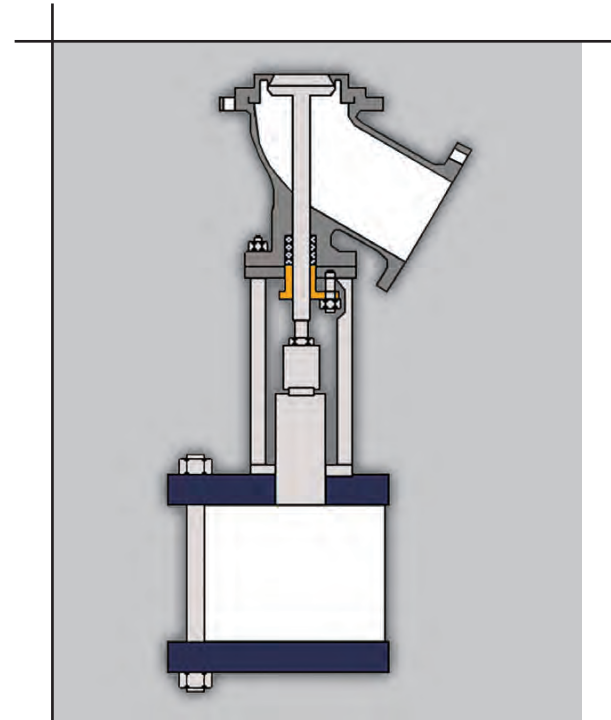

Model 18BS disc lowering valve with stuffing box seal

Disc Bottom Outlet Valve – Sealing Arrangements

Disc valves are available with a number of different sealing options:

- Model 25BS is typically a Hastelloy or stainless steel valve with a stuffing box seal to the outside.
- Model 25BH is usually a metal or stainless steel valve with a Hastelloy or metal bellows and a back up stuffing box seal.
- Model 25BF is a Teflon or glass lined valve with bellows and back up stuffing box seal.
- Model 25BM features a Teflon or rubber diaphragm seal.

All disc valves can be provided with a “TA Luft” (exacting German environmental emissions standard) compatible stuffing box seal.

Sealing to process options include metal to metal, hard faced material options and PTFE sealing ring.

Valve Bodies

The valve bodies for all models would usually be in various stainless steel grades, but can also be provided in any available castable or weldable material.

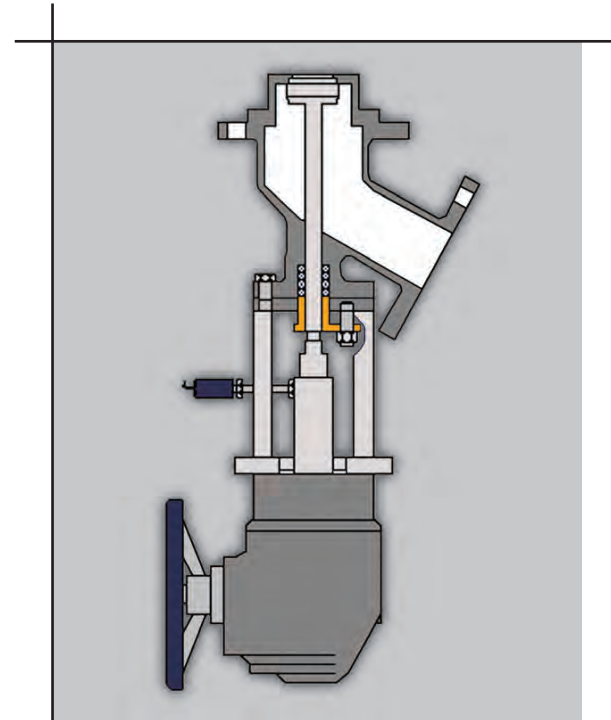

Model 24BS disc lowering valve with stuffing box seal

For the pharmaceutical industry for example, stainless steel grades such as 1.4435 (BN2) and easily polished 316L, 1.4439 or 1.4539 are used. For higher corrosion resistance we can provide Duplex, Alloy 59, Hastelloy C22, C276, B2, B3, Titanium, Zirconium and many others.

Alternatively, cast steel or stainless steel valves can be delivered with isostatically sintered PTFE or glass lined bodies.

Features of Disc Bottom Outlet Valves

Core features of Disc Bottom Outlet Valves include a robust design and construction, high adaptability, and no dead space. Each SchuF Bottom Outlet Valve is adapted to fit the requirements of the proposed application, whether it be a non standard size connection, highly abrasive material, or low contamination requirements.

Feature Overview

■ Crust Breaking

Disc rising valves (Models 19 or 25) automatically break any crust that may have formed at the bottom of the reactor as they open. They are therefore suited to media containing solids or crystals.

■ Dead Space Free

All valves are fitted exactly to the reactor nozzle to ensure that there is no dead space at the bottom of the reactor. The valves are designed to allow the vessel and themselves to drain completely.

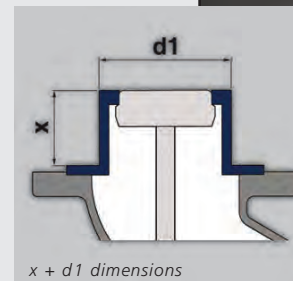

■ Sealing to Atmosphere

To eliminate leakage to the outside, all disc valves can be fitted with a PTFE extruded bellows (Type 25BF), a metal bellows (Type 25BH), or a PTFE diaphragm (25BM). A “TA Luft” compatible stuffing box is also available.

■ Clean-in-place (CIP)

All valves can be fitted with flushing ports (standard with lined valves Type 25BF) allowing cleaning of the valve while a reaction is taking place in the vessel.

■ Temperature Sensing

Placing a temperature sensor in the valve disc ensures that the reactor’s contents can be measured even when the batches are very small. The sensor can be removed for calibration whilst the valve is still in service.

■ Multi Purpose

Stainless steel valves are usually sufficient for the food and biochemical industry. For multi-purpose batch plants, producing a variety of chemicals and active ingredients including acids and bases, valves with a higher chemical resistance may be required. SchuF can supply valves in Hastelloy, Titanium and Zirconium or with linings in glass-, rubber- PTFE- and Tantalum.

■ Contamination Free

To avoid the possibility of cross contamination and remnants in gaps, stationary FDA approved solutions such as an o-ring seal, lip seal or expandable seat can be provided. Model 24AV “Sterile Valve” has a single part seat body and disc spindle construction, which ensures that all parts of the valve’s interior can be cleaned and sterilised.

■ Fire-safety

To limit the damage a fire may cause it is vital that reactors, storage vessels and their outlet valves remain intact to prevent feeding the fire or polluting the extinguishing agents. All our valves can be offered in a fire-safe version.

We are the only manufacturer to be able to do so even for PTFE and glass-lined valves.

■ Integrated Sampling and Flushing

Often space and process consideration prohibit the use of an extra sampling system, especially when there is the danger that the submerged sampling pipe can become blocked, or if there are pollution or cost reasons, not to discard the whole sample.

If space is at a premium, it is possible to combine a wafer type sampling valve with a disc valve in a SchuF patented combination.



Model 24BC disc lowering valve

Pharmaceutical and Fine Chemical Industry

SchuF disc valves have seen extensive service in the bulk pharmaceutical and fine chemical industries. They are often used in the production of core active ingredient acids and vitamins.

Over the past 15 years the dual pressure of rationalisation and safety & environment regulation have led to many valve developments. SchuF is at the forefront of these developments with a number of innovations:

- Expandable blow up seat (to fill potential dead spaces)
- GMP compliant disc valves
- Fully cleanable and flushable in place features
- Seat-less disc valves

Sterile Valve (Model 24AV)

Sterile valves are widely used in the Pharmaceutical industry and can be supplied to 4 inches as standard or larger sizes as required. The SchuF 24AV sterile valve is a highly versatile valve that can be used as a drain, angle or sampling valve. They are fitted at the bottom of stainless steel, Hastelloy, or glass lined fermentors and reactors. The disc opens into the valve and can seal directly against the reactor flange, thereby eliminating the possibility of a gap between the seat and reactor. Additionally the disc can be contoured to suit the medium drainage properties.



Model 24AV Sterile Valve

Good Manufacturing Practice (GMP) Valves

SchuF offers a complete range of valves which conform to GMP standards. The valves open into the vessel or valve, with a stuffing box seal, bellows seal or a diaphragm seal. The valves have the following characteristics:

- Completely dead space free
- Easily flushable
- Surfaces can be polished to $Ra < 0.2 \mu$
- Crevice free

These valves are ideal for batch processes, where even the smallest contamination from the previous batch could be fatal. There are a variety of sealing options for GMP compliance as listed below.

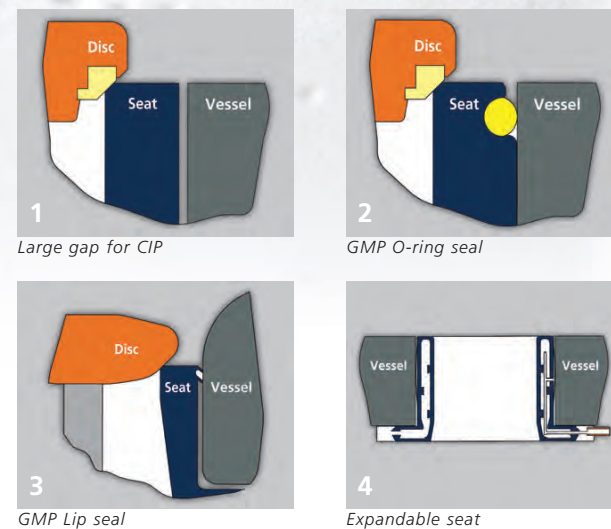

The gap between seat and vessel can be designed CIP conform to be flushed out between different batches (1), or else can be closed off from the process in the vessel using either an O-ring (2), a lip seal (3) or an expandable seat (4).

Dimensions Example for GMP Compliant 25BF

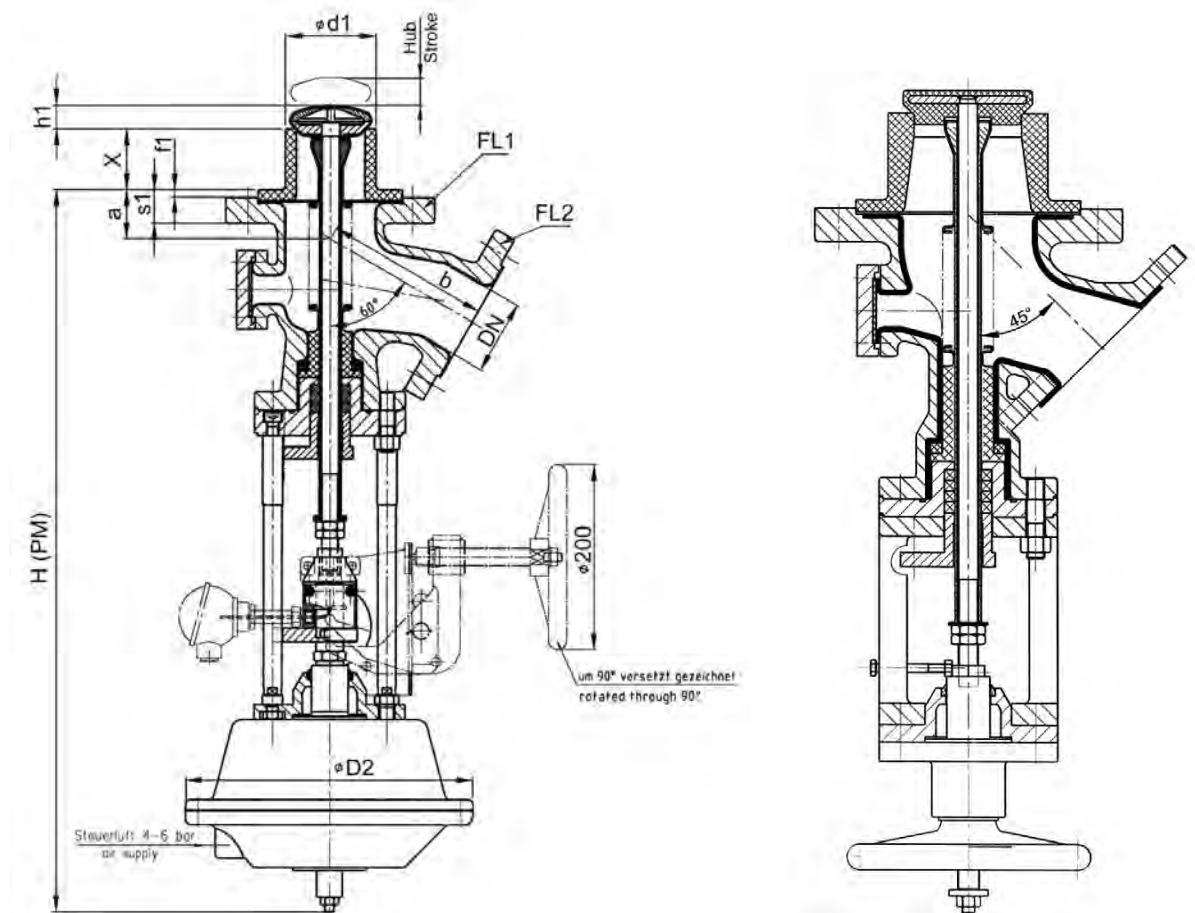

Valve dimension table for Disc BOV model 25BF (PTFE / glass lined)

Size (Inch)	60°				45°		
	80/50 3"/2"	100/80 4"/3"	150/100 6"/4"	200/150 8"/6"	80/50 3"/2"	100/80 4"/3"	150/100 6"/4"
x Standard	52	66	81	min 40	52	66	81
d1 Standard	79	99	148	min 190	79	99	148
x min-max	52 - 100	66 - 150	81 - 180	40 - 180	52 - 100	66 - 150	81 - 180
a	57	55	75	110	14	14	14
b	167	180	200	240	115	155	175
h1	18	25	23	42	18	25	23
H (PM)	710	790	790	875	710	820	840
H (NF)	500	570	570	775	500	600	620
H (PS)	480	480	500	700	480	510	550
HUB	35	35	35	45	35	35	35
Hb	0	75	115	45	0	50	70
D2	315	315	315	390	315	315	315
s1	38	38	40	51	38	38	40

All dimensions are in mm unless otherwise stated. Dimensions for other BOV models are available on request.

Choosing the appropriate Disc Bottom Outlet Valve

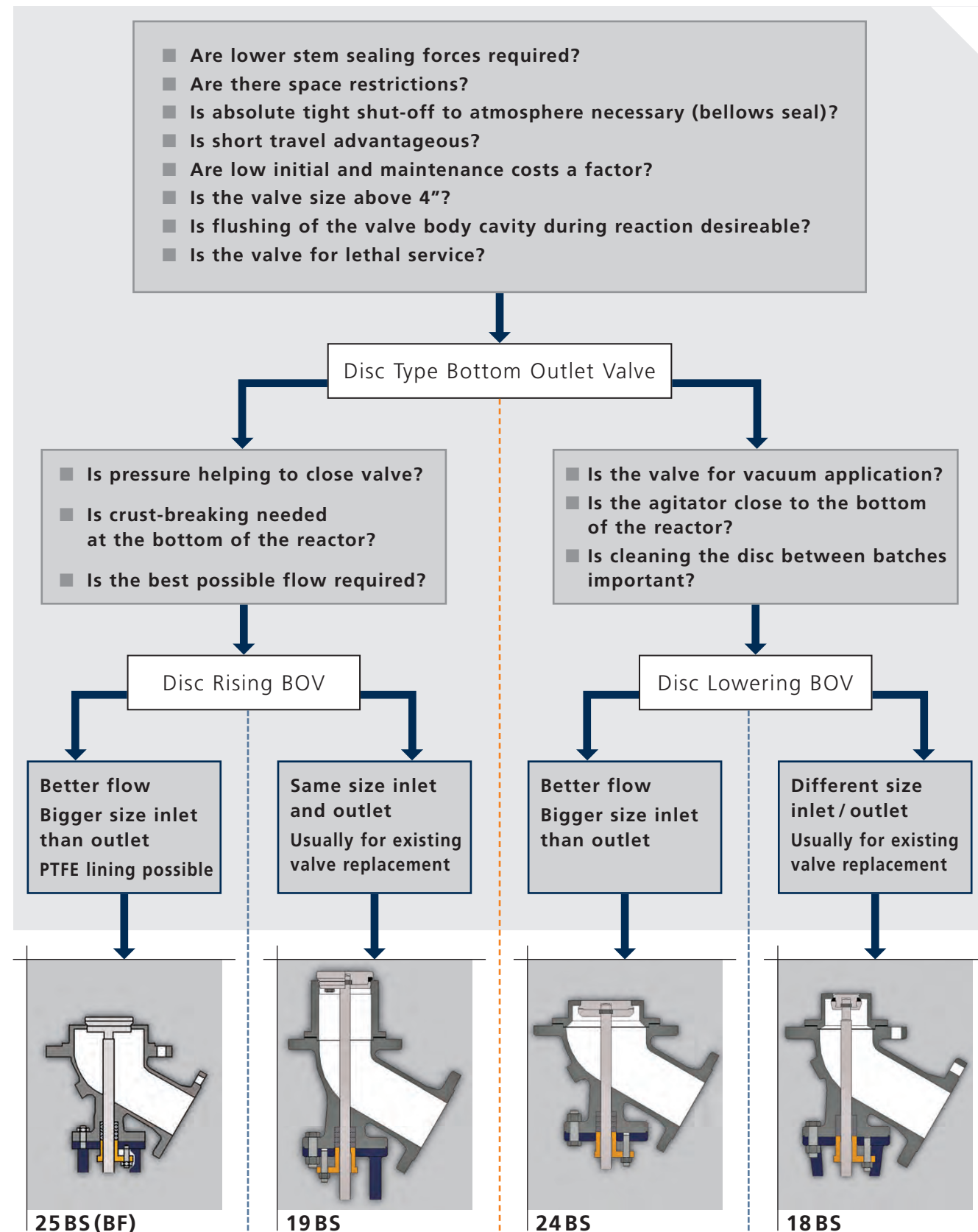

Disc Bottom Outlet Valve Specifications

	Standard	Optional
Size	1" to 18" as standard	Larger on request
Body	Stainless steel 1.4408 (CF-8M)	304, 316L, Duplex, Hastelloy, Monel, Titanium, Nickel, Inconel, Incoloy, etc.
Valve lining	n/a	PTFE, glass, ceramic or rubber
Outlet	45° or 60°	90°
Disc	Stainless steel 1.4571 (316 Ti)	Glass lined, hard faced, tantalum clad, PTFE and all materials under "Body-Optional"
Spindle	Stainless steel 1.4571 (316 Ti)	Hast C276 and all materials under "Body-Optional"
Seat	Stainless steel, replaceable	PTFE lined and all materials under "Body-Optional"
Temperature	minus 10° to 230° C	Higher or lower on request
Pressure	ASME 150, PN16 & PN40	Up to ASME 2500, PN320 or higher on request
Temperature Sensors	n/a	2 x PT 100 sensors with tantalum cap on disc, or stainless steel rod in disc
Actuators	Manual, pneumatic, hydraulic or electric	Side mounting is available Actuation speed down to 0,1 sec.
Fire safe	n/a	Fire safe to BS 6755 Pt. 2 *
Heating Jacket	n/a	On request
Surface coating	n/a	Anodising, Canadising, Titanium Nitriding, Ceramic and Tungsten

* European safety standard similar to API 607.

Atmospheric Sealing Options:

Type BS	stuffing box with packing rings for all models
Type BH	metal bellows, zero emissions to atmosphere, and emergency stuffing box
Type BF	PTFE bellows, zero emissions to atmosphere, and emergency stuffing box
Type BM	diaphragm sealed, zero emissions to atmosphere, and emergency stuffing box

Process and Seat Sealing Options:

Process: PTFE sealing ring, metal to metal and hard faced material options
Seat: O-ring, lip seal and expandable seat

Additional Options:

■ Flushing/Purging connections	■ CIP / GMP	■ Jacking bolts
■ FDA compliant materials	■ Manual over-ride	■ Disc contouring
■ Internal/External polishing	■ T or spool piece	■ Tapered seats
■ Limit switches	■ Leak detection	■ Live loaded packing
	■ Disc grinding	■ Wipers
	■ Solenoid valves	■ Positioners



Industry Application Case Studies for Disc Valves

PTA Application Case Study

A major North American producer of PTA faced a problem, which had caused a critical PTA process line to run inefficiently. The customer had installed ball valves at the entrance to transfer lines between crystallisers which regularly got stuck due to build up of slurry around and in the ball itself. SchuF resolved the problem by providing a self draining Disc BOV with integrated flushing and no dead space. The combination of a dead space free connection and flushing eliminated the build up of the slurry. Plant efficiency increased significantly thereafter.

Mining Application Case Study

A European Tungsten Carbide mining company faced the problem that an on-off valve installed after a depressurization vessel leaked, and had to be maintained weekly. In this secondary process, tungsten is mixed with caustic soda at high pressure and a highly abrasive slurry results. By replacing the on-off valve with a SchuF Disc BOV the company was able to reduce maintenance to annual checks. According to the plant manager "The valve has worked so well, that I can't even remember when we last had to do any maintenance"



Alumina Service Case Study

The production of alumina requires valves that can withstand significant abrasion and scaling. One important producer of Alumina in Brazil was faced with the problem that their existing feed valve seats would regularly get stuck and consequently not close. This led to equipment damage and production down time. SchuF resolved the problem by designing a special disk grinding mechanism specifically suited to Alumina slurry. With the new design SchuF Disc BOV the alumina producer now has no issues with valve closure.

Polymer Service Case Study

SchuF disc valves are used extensively in the Polymer industry as they are ideal for injecting low viscosity feedstocks. For one particular Asian customer where Vinyl Chloride is used as a feedstock, the disc and seat were contoured to exactly match the vessel wall and a special bellow seal was supplied. This ensured that no atmospheric pollution would take place. The customer reported excellent valve sealing performance.

SchuF Valve Portfolio

SchuF has delivered over one million valves during its almost 100 year history to a wide variety of industries in over 50 countries worldwide.

Headquartered near Frankfurt in Germany, the company has additional design and manufacturing centres in Brazil, India, Ireland and the United States.

The SchuF group has sales and agent offices covering almost every country in the world.

We manufacture valve products that control, isolate, divert, and sample liquids, gases, powders, and slurries. Our product range of engineered, customised valves includes:

Bottom Outlet Valves	Control Valves	Coker Valves	Diverter & Changeover Valves	In-Line Valves	Sampling Valves	Other Products
Piston / Ram Bottom Outlet	Angle Control Valve	Coker IsoPlug	Multiport Diverter Valve	Lift Plug On-Off Isolation	Line Sampling Valve	Line Blinds Cam Set & Stacey
Disc lowering Bottom Outlet	Globe Control Valve	Coker SwitchPlug	Lift Plug Diverter Valve	Lift Plug Switching	Screw-In Sampling Valve	Spray Rinse Valve
Disc rising Bottom Outlet	Wafer Control Valve	Coker ControlPlug	Changeover Valve	Lift Plug Bypass	Submersed Sampling Valve	High Pressure Angle Valve
	Backpressure Control Valve	Coker Quench Valve	Changeover Combination Valve	Y-Globe Valve	Wafer Sampling Valve	Distributor Valve
	Automatic Recirculation Valve				Sampling Systems	Steam Injection Valve
						In-lying Disc Valve

Sample Bottom Outlet Valve Client List:

- Aker Kvaerner
- Astra Zeneca
- BASF
- BAYER
- Boehringer Ingelheim
- Novartis
- Degussa
- Du Pont
- Formosa Plastics
- GE
- GlaxoSmithKline
- Honeywell
- Indorama
- Ineos
- Lurgi
- Merck
- Mitsui
- Petrobras
- Pfizer
- Reliance
- Roche
- Samsung
- Sandoz
- Sanofi Aventis
- Schering
- Shell
- Shenhua
- Sinopec
- Solvay
- Yisheng
- Uhde Inventa Fischer



Model 25B5